

HE-LINK 10Gb/s 1550nm X2 ZR Transponder HLX2-55192-ZR

Features

- ◆ X2 MSA Compliant
- ◆ 70-PIN connector
- ◆ SC duplex receptacle package
- ◆ Cooled EA-DFB/APD-PD
- ◆ Power supply: +5.0 V, +3.3 V, APS:+1.2 V
- ◆ Power Dissipation 4W Maximum
- ◆ 0°C to 70°C Operating Case Temperature
- ◆ Digital Diagnostic Monitoring
- ◆ Management and control with MDIO 2-wire bus
- ◆ XAUI electrical interface 4 x 3.125 Gb/s Ethernet
- ◆ 80km ER 10GBE
- ◆ RoHS6 compliant and lead free 

Applications

- ◆ 10 Gb/s Ethernet transmission systems

Absolute Maximum Ratings

Parameter	Symbol	Min	Max	Unit
Supply Voltage+5V	Vcc5		6.0	V
Supply Voltage_3.3V	Vcc3		4	V
Supply Voltage APS	Vaps		2	V
Storage Temperature	Tst	-20	85	°C
Optical Input Received Power	PIN	-	-7	dBm

Operating Conditions

Parameter	Symbol	Min	Typical	Max	Unit
Operating Case temperature	Tca	0	-	70	°C
Supply Voltage+5V	Vcc5	4.75	5	5.25	V
Supply Current+5V	Icc5			500	mA
Supply Voltage_3.3V	VCC3	3.14	3.3	3.47	V
Supply Current+3.3V	Icc3			1000	mA
Supply Voltage APS	Vaps	1.14	1.2	1.26	V
Supply Current APS	Iaps			1100	mA
Module Power Dissipation	Pm	-		4	W

Transmitter Specifications – Optical

Parameter	Symbol	Min	Typical	Max	Unit
Center Wavelength	λ_c	1464.5		1617.5	nm
Center wavelength stability	$\Delta\lambda_D$	-6.5	λ_c	6.5	nm
Optical Transmit Power	Po	0		4	dBm
Optical Transmit Power (disabled)	Ptx-dis	-	-	-40	dBm
Extinction Ratio	ER	9		-	dB
Side Mode Suppression Ratio	SMSR	30	-	-	dB
Eye Mask	IEEE 802.3ae Compliant				

Transmitter Specifications – Electrical

Parameter	Symbol	Min	Typical	Max	Unit
Data Rate (TXLINE0-3)	TX-xaui	-	3125	-	Mbps
Differential impedance	Zo	80	100	120	Ω
Differential Input Amplitude	Vin P-P	160	-	2000	mVpp
Input Rise/Fall	TR / TF	60	-	130	ps
Differential Impedance of Zin	Zin	-	100	-	ohm

Receiver Specifications – Optical

Parameter	Symbol	Min	Typical	Max	Unit
-----------	--------	-----	---------	-----	------

Input Operating Wavelength	λ	1260	-	1600	nm
Received power 1	Rpo	-24	-	-7	dBm
Maximum Input Power	RX-overload	-7	-	-	dBm
Reflectance	Rrx	-	-	-27	dB

Receiver Specifications – Electrical

Parameter	Symbol	Min	Typical	Max	Unit
Data Rate (TXLINE0-3)	RX-xaui		3125		Mbps
Supply Voltage	VccRX	3.13	3.3	3.47	V
Differential Output Amplitude	Vout P-P	800	-	1600	mV
Rise/Fall Time	Tr / Tf	50	-	90	ps
Differential Impedance of Zout	Zout	-	100	-	ohm

Signal Specifications – Electrical

Parameter	Symbol	Min	Typ	Max	Units
1.2 V CMOS					
Input High Voltage	VIL(MAX)	-	-	0.36	V
Input Low Voltage	VIH(MIN)	0.84	-	1.25	V
Capacitance		-	-	320	pF
Pull Up Resistance	Rpull	10k	-	22k	ohm
MDIO I/O					
Output Low Voltage	VOL	-0.3	-	0.2	V
Output Low Current	IOL	-	-	4	mA
Input High Voltage	VIH	0.84	-	1.5	V
Input Low Voltage	VIL	-0.3	-	0.36	V
Pull-up Supply Voltage	VPULL	1.14	1.2	1.26	
Input Capacitance	CIN	-	-	10	Pf
Load Capacitance	CLOD	-	-	470	Pf
External Pull-up Resistance	EPULL	200	-	-	Ohm

Pin Definitions

Pin No	Name	Dir	Function	Notes
1	GND		Electrical Ground	1
2	GND		Electrical Ground	1

3	GND		Electrical Ground	1
4	5.0V		Power	2
5	3.3V		Power	2
6	3.3V		Power	2
7	APS =1.2V		Adaptive Power Supply	2
8	APS =1.2V		Adaptive Power Supply	2
9	LASI		Open Drain Compatible 10K-22K pull up on host. Logic High: Normal Operation Logic Low: LASI Asserted	3
10	RESET	I	Open Drain compatible. 10-22K pull-up on transceiver Logic high = Normal operation Logic low = Reset Minimum reset assert time 1 ms	3
11	VEND SPECIFIC		Vendor Specific Pin. Leave unconnected when not in use.	6
12	TX ON/OFF	I	Open Drain compatible. 10-22K pull-up on transceiver Logic high = Transmitter On (capable) Logic low = Transmitter Off (always)	3
13	RESERVED		Reserved	3
14	MOD DETECT	O	Pulled low inside module through 1k	
15	VEND SPECIFIC		Vendor Specific Pin. Leave unconnected when not in use.	6
16	VEND SPECIFIC		Vendor Specific Pin. Leave unconnected when not in use.	6
17	MDIO	I/O	Management Data IO	3, 4
18	MDC	I	Management Data Clock	3, 4
19	PRTAD4	I	Port Address Bit 4 (Low = 0)	3
20	PRTAD3	I	Port Address Bit 3 (Low = 0)	3
21	PRTAD2	I	Port Address Bit 2 (Low = 0)	3
22	PRTAD1	I	Port Address Bit 1 (Low = 0)	3
23	PRTAD0	I	Port Address Bit 0 (Low = 0)	3
24	VEND SPECIFIC		Vendor Specific Pin. Leave unconnected when not in use.	6
25	APS SET		Feedback input for APS	
26	RESERVED		Reserved for Avalanche Photodiode use.	6
27	APS SENSE		APS Sense Connection	
28	APS =1.2V		Adaptive Power Supply	2
29	APS =1.2V		Adaptive Power Supply	2
30	3.3V		Power	2
31	3.3V		Power	2
32	5.0V		Power	2
33	GND		Electrical Ground	1
34	GND		Electrical Ground	1

35	GND		Electrical Ground	1
36	GND		Electrical Ground	1
37	GND		Electrical Ground	1
38	RESERVED		Reserved	
39	RESERVED		Reserved	
40	GND		Electrical Ground	1
41	RX LANE0+	O	Module XAUI Output Lane 0+	5
42	RX LANE0-	O	Module XAUI Output Lane 0-	5
43	GND		Electrical Ground	1
44	RX LANE1+	O	Module XAUI Output Lane 1+	5
45	RX LANE1-	O	Module XAUI Output Lane 1-	5
46	GND		Electrical Ground	1
47	RX LANE2+	O	Module XAUI Output Lane 2+	5
48	RX LANE2-	O	Module XAUI Output Lane 2-	5
49	GND		Electrical Ground	1
50	RX LANE3+	O	Module XAUI Output Lane 3+	5
51	RX LANE3-	O	Module XAUI Output Lane 3-	5
52	GND		Electrical Ground	1
53	GND		Electrical Ground	1
54	GND		Electrical Ground	1
55	TX LANE0+	I	Module XAUI Input Lane 0+	5
56	TX LANE0-	I	Module XAUI Input Lane 0-	5
57	GND		Electrical Ground	1
58	TX LANE1+	I	Module XAUI Input Lane 1+	5
59	TX LANE1-	I	Module XAUI Input Lane 1-	5
60	GND		Electrical Ground	1
61	TX LANE2+	I	Module XAUI Input Lane 2+	5
62	TX LANE2-	I	Module XAUI Input Lane 2-	5
63	GND		Electrical Ground	1
64	TX LANE3+	I	Module XAUI Input Lane 3+	5
65	TX LANE3-	I	Module XAUI Input Lane 3-	5
66	GND		Electrical Ground	1
67	RESERVED		Reserved	
68	RESERVED		Reserved	
69	GND		Electrical Ground	1
70	GND		Electrical Ground	1

Notes:

- 1) Ground connections are common for TX and RX.
- 2) All connector contacts are rated at 0.5A nominal.
- 3) 1.2V CMOS compatible.
- 4) MDIO and MDC timing must comply with IEEE802.3ae, Clause 45.3

- 5) XAUI output characteristics should comply with IEEE802.3ae Clause 47.
- 6) Transceivers will be MSA compliant when no signals are present on the vendor specific pins.

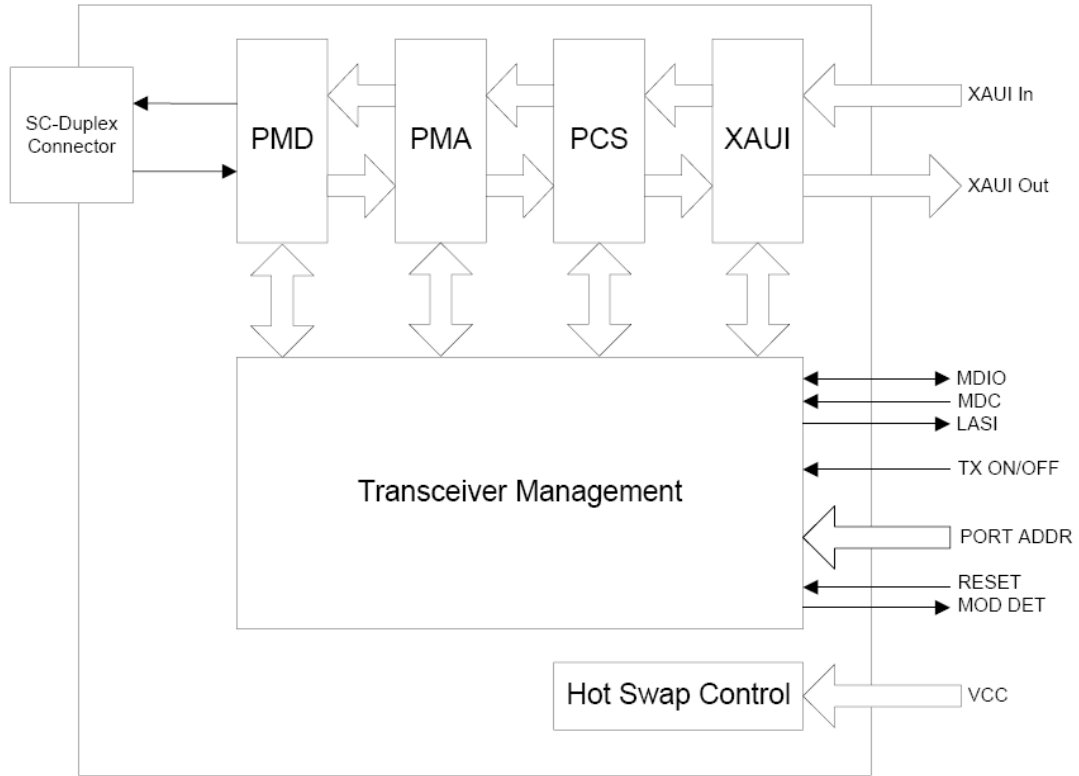

Figure1. Functional Diagram of Typical X2 Style Transceiver

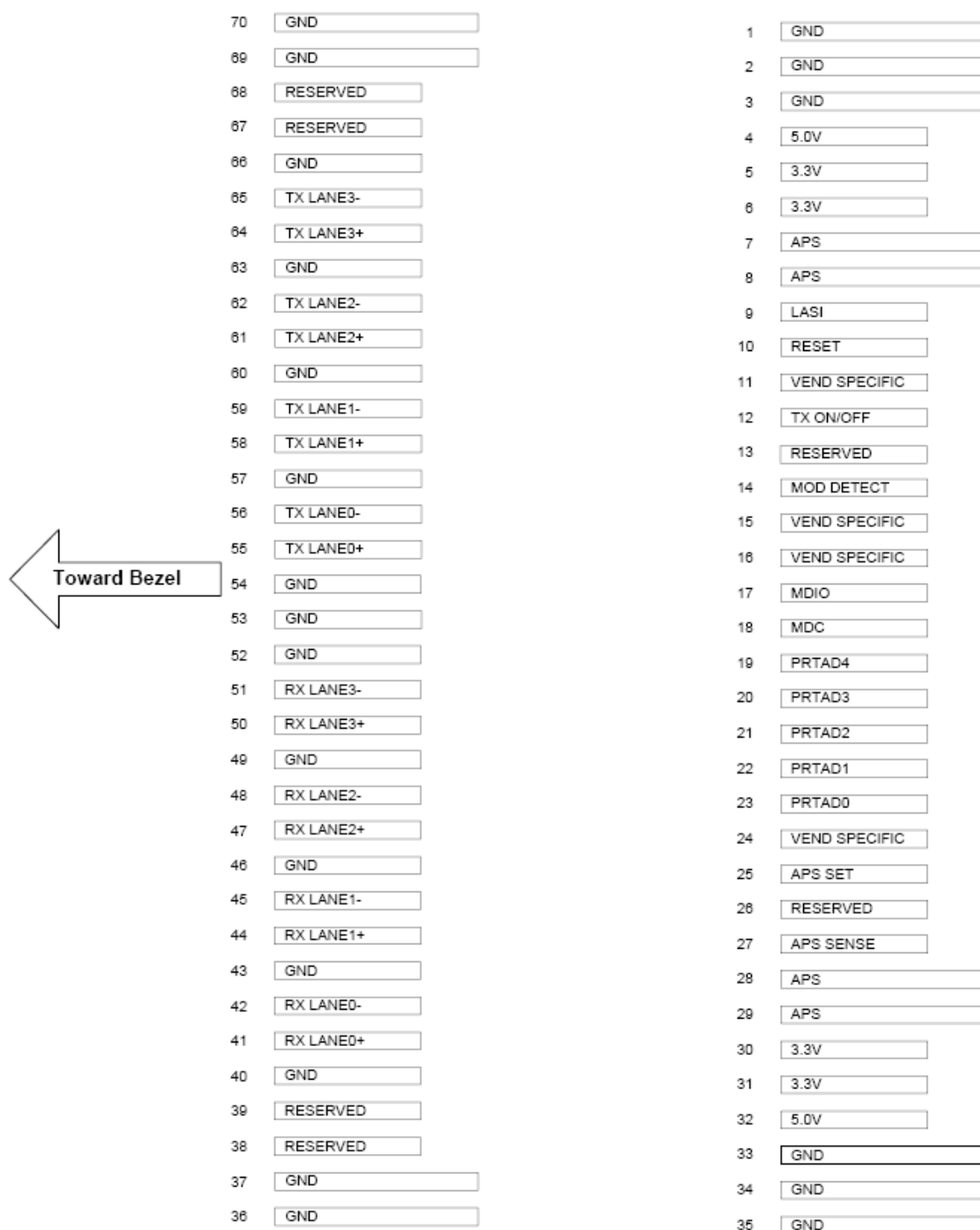
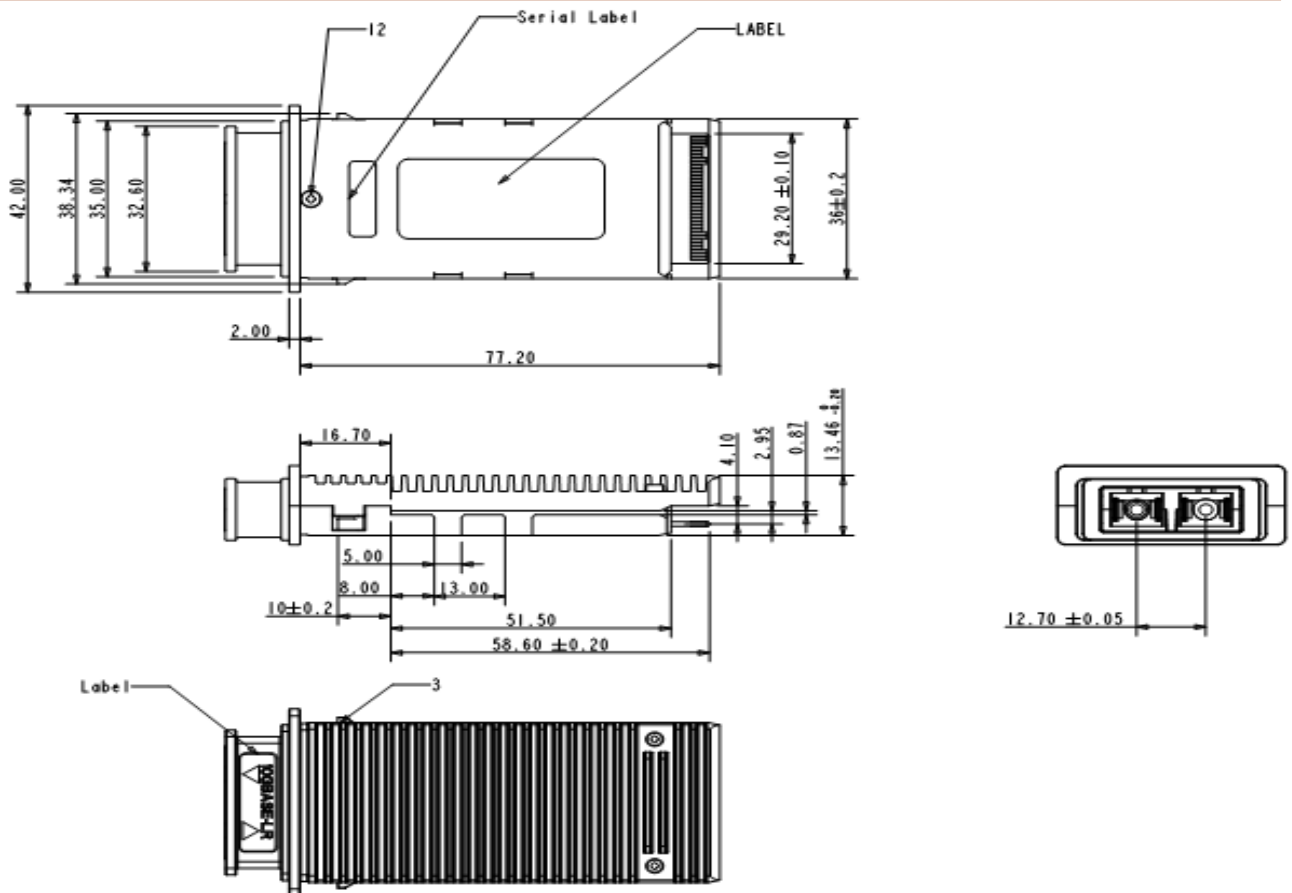

Figure2.Electrical Pin-out Details



Dimensions in mm

Figure3. Mechanical Dimensions

Regulatory Compliance

HE-LINKcom X2 Transponder is designed to be Class I Laser safety compliant and is certified per the following standards:

Feature	Agency	Standard	Certificate / Comments
Laser Safety	FDA	CDRH 21 CFR 1040 and Laser Notice No. 50	1120291-000

Product Safety	UL	UL and CUL EN60950-2:2007	WT10093765-D-E-E
Environmental protection	SGS	RoHS Directive 2002/95/EC	GZ1001008706/CHEM
EMC	WALTEK	EN 55022:2006+A1:2007 EN 55024:1998+A1+A2:2003 -	WT10093768-D-E-E

Ordering information

Part Number	Product Description
HLX2-55192-ZR	X2, 80km(ZR), 0°C ~ 70°C, Cooled EA-DFB/APD

Important Notice

Performance figures, data and any illustrative material provided in this data sheet are typical and must be specifically confirmed in writing by HE-LINKcom before they become applicable to any particular order or contract. In accordance with the HE-LINKcom policy of continuous improvement specifications may change without notice.

The publication of information in this data sheet does not imply freedom from patent or other protective rights of HE-LINKcom or others. Further details are available from any HE-LINKcom sales representative.

sales@HE-LINKcom.com
<http://www.HE-LINKcom.com>