

## HE-LINK 10GBASE -LRM , 220m Reach HLX2-31192-LRM

### Features

- ◆ Compatible with X2 MSA Rev2.0b
- ◆ Support of IEEE 802.3ae 10GBASE-LR at 10.3125Gbps
- ◆ Transmission Distance up to 220m(MMF)
- ◆ SC Receptacle 1310nm DFB Laser
- ◆ SC Duplex Optical Connector
- ◆ Hot Pluggable 70-PIN Connector with XAUI Electrical Interface
- ◆ Management and control via MDIO 2-wire interface
- ◆ Power Supply :+3.3V, APS(+1.2V)
- ◆ Power Dissipation 4W Maximum
- ◆ Diagnostic Optics Monitoring
- ◆ Temperature Range: 0~ 70 °C
- ◆ ROHS6 Compatible 

### Applications

- ◆ 10GE Ethernet switches and routers
- ◆ 10GE Core-routers
- ◆ 10GE Storage
- ◆ Other 10Gbps Ethernet Transmission System

### Absolute Maximum Ratings

Parameter	Symbol	Min	Max	Unit	Ref.
Storage Ambient Temperature Range		-40	+85	°C	non condensing
Powered case Temperature Range		0	+70	°C	non condensing
Adaptable Power Supply (APS)	Vapsense	0	1.5	V	Voltage @ Pin APS Sense
Supply Voltage Range @ 3.3V	Vcc3	-0.5	4.0	V	

### Operating Conditions

Parameter	Symbol	Min	Typical	Max	Unit
-----------	--------	-----	---------	-----	------

Operating Case Temperature	Tc	0		+70	°C
Power Supply Voltage	V <sub>CC3</sub>	3.14	3.3	3.47	V
	V <sub>APS</sub>	1.152	1.2	1.248	
Power Dissipation	PD		3.5	4	W

### Transmitter Characteristics

Parameter	Symbol	Min.	Typ.	Max.	Unit	Note
Operating Range	lop	0		220	m	1
Operating Data Rate	DR		10.3125		Gb/s	
Lanuch Power in OMA	P <sub>oma</sub>	-4.5		1.5	dBm	
Average Lanuch Power	P <sub>avg</sub>	-6.5		0.5	dBm	
Input Centre Wavelength	$\lambda$	1260	1310	1355	nm	
RMS Spectral width at 1260 RMS Spectral width at 1260-1300 RMS Spectral width at 1300-1355	L <sub>rms</sub>	--	--	2.4 Figre 1 4	nm	
Extinction Ratio	ER	3.5	--			
Transmitter Waveform and Dispersion Penalty	TWDP			4.7	dB	
Peak lanuch Power	OMA			3	dB	
RIN20 OMA	RIN			-128	dB/HZ	
Uncorrelated jitter (rms)	Jitter			0.033	UI	
Optical Return Loss Tolerance	ORLT	20			dB	

Note: 1.220m in OM1, OM2, OM3

### Receiver Characteristics

Parameter	Symbol	Min.	Typ.	Max.	Unit	Note
Operating Data Rate			10.3125		Gb/s	
Input Centre Wavelength	$\lambda$	1260		1355	nm	
Overload in OMA	P <sub>o</sub>	1.5			dBm	
Stressed Sensitivity in OMA	OM <sub>ast</sub>			-6.5	dBm	
Sensitivity in OMA for symmetrical test	P <sub>min</sub>			-6	dBm	1
Receiver Reflectance	ORL			-12	dB	

Note: 1. Measured at 10.3125Gb/s, Non-framed PRBS2<sup>31</sup>-1, NRZ

### XAUI I/O Characteristics

Parameter	Symbol	Min.	Typ.	Max.	Unit	Note
XAUI Data Rate	DR		3.125		Gb/s	
XAUI Baud Rate Tolerance		-100		+100	ppm	Relative Tolerance

Differential Input Voltage Swing		220		1600	mv	8B/10B Coded Input Signal
Differential Output Voltage Swing		800		1600	mVp-p	RLOAD = 100Ω ± 5%
Differential Input Impedance		80	100	120	Ω	
Total Output Jitter	TJXAU1			0.35	UI	no pre-equalization
Total Deterministic Output Jitter	DJXAU1			0.17	UI	no pre-equalization

## Signal Specifications – Electrical

Parameter	Symbol	Min	Typ	Max	Units
1.2 V CMOS					
Input High Voltage	VIL(MAX)	-	-	0.36	V
Input Low Voltage	VIH(MIN)	0.84	-	1.25	V
Capacitance		-	-	320	pF
Pull Up Resistance	Rpull	10k	-	22k	ohm
MDIO I/O					
Output Low Voltage	VOL	-0.3	-	0.2	V
Output Low Current	IOL	-	-	4	mA
Input High Voltage	VIH	0.84	-	1.5	V
Input Low Voltage	VIL	-0.3	-	0.36	V
Pull-up Supply Voltage	VPULL	1.14	1.2	1.26	
Input Capacitance	CIN	-	-	10	Pf
Load Capacitance	CLOD	-	-	470	Pf
External Pull-up Resistance	EPULL	200	-	-	Ohm

## Pin Definitions

Pin No	Name	Dir	Function	Notes
1	GND		Electrical Ground	1
2	GND		Electrical Ground	1
3	GND		Electrical Ground	1
4	5.0V		Power	2
5	3.3V		Power	2

6	3.3V		Power	2
7	APS =1.2V		Adaptive Power Supply	2
8	APS =1.2V		Adaptive Power Supply	2
9	LASI		Open Drain Compatible 10K-22K pull up on host. Logic High: Normal Operation Logic Low: LASI Asserted	3
10	RESET	I	Open Drain compatible. 10-22K pull-up on transceiver Logic high = Normal operation Logic low = Reset Minimum reset assert time 1 ms	3
11	VEND SPECIFIC		Vendor Specific Pin. Leave unconnected when not in use.	6
12	TX ON/OFF	I	Open Drain compatible. 10-22K pull-up on transceiver Logic high = Transmitter On (capable) Logic low = Transmitter Off (always)	3
13	RESERVED		Reserved	3
14	MOD DETECT	O	Pulled low inside module through 1k	
15	VEND SPECIFIC		Vendor Specific Pin. Leave unconnected when not in use.	6
16	VEND SPECIFIC		Vendor Specific Pin. Leave unconnected when not in use.	6
17	MDIO	I/O	Management Data IO	3, 4
18	MDC	I	Management Data Clock	3, 4
19	PRTAD4	I	Port Address Bit 4 (Low = 0)	3
20	PRTAD3	I	Port Address Bit 3 (Low = 0)	3
21	PRTAD2	I	Port Address Bit 2 (Low = 0)	3
22	PRTAD1	I	Port Address Bit 1 (Low = 0)	3
23	PRTAD0	I	Port Address Bit 0 (Low = 0)	3
24	VEND SPECIFIC		Vendor Specific Pin. Leave unconnected when not in use.	6
25	APS SET		Feedback input for APS	
26	RESERVED		Reserved for Avalanche Photodiode use.	6
27	APS SENSE		APS Sense Connection	
28	APS =1.2V		Adaptive Power Supply	2
29	APS =1.2V		Adaptive Power Supply	2
30	3.3V		Power	2
31	3.3V		Power	2
32	5.0V		Power	2
33	GND		Electrical Ground	1
34	GND		Electrical Ground	1
35	GND		Electrical Ground	1
36	GND		Electrical Ground	1
37	GND		Electrical Ground	1

38	RESERVED		Reserved	
39	RESERVED		Reserved	
40	GND		Electrical Ground	1
41	RX LANE0+	O	Module XAUI Output Lane 0+	5
42	RX LANE0-	O	Module XAUI Output Lane 0-	5
43	GND		Electrical Ground	1
44	RX LANE1+	O	Module XAUI Output Lane 1+	5
45	RX LANE1-	O	Module XAUI Output Lane 1-	5
46	GND		Electrical Ground	1
47	RX LANE2+	O	Module XAUI Output Lane 2+	5
48	RX LANE2-	O	Module XAUI Output Lane 2-	5
49	GND		Electrical Ground	1
50	RX LANE3+	O	Module XAUI Output Lane 3+	5
51	RX LANE3-	O	Module XAUI Output Lane 3-	5
52	GND		Electrical Ground	1
53	GND		Electrical Ground	1
54	GND		Electrical Ground	1
55	TX LANE0+	I	Module XAUI Input Lane 0+	5
56	TX LANE0-	I	Module XAUI Input Lane 0-	5
57	GND		Electrical Ground	1
58	TX LANE1+	I	Module XAUI Input Lane 1+	5
59	TX LANE1-	I	Module XAUI Input Lane 1-	5
60	GND		Electrical Ground	1
61	TX LANE2+	I	Module XAUI Input Lane 2+	5
62	TX LANE2-	I	Module XAUI Input Lane 2-	5
63	GND		Electrical Ground	1
64	TX LANE3+	I	Module XAUI Input Lane 3+	5
65	TX LANE3-	I	Module XAUI Input Lane 3-	5
66	GND		Electrical Ground	1
67	RESERVED		Reserved	
68	RESERVED		Reserved	
69	GND		Electrical Ground	1
70	GND		Electrical Ground	1

Notes:

- 1) Ground connections are common for TX and RX.
- 2) All connector contacts are rated at 0.5A nominal.
- 3) 1.2V CMOS compatible.
- 4) MDIO and MDC timing must comply with IEEE802.3ae, Clause 45.3
- 5) XAUI output characteristics should comply with IEEE802.3ae Clause 47.
- 6) Transceivers will be MSA compliant when no signals are present on the vendor specific pins.

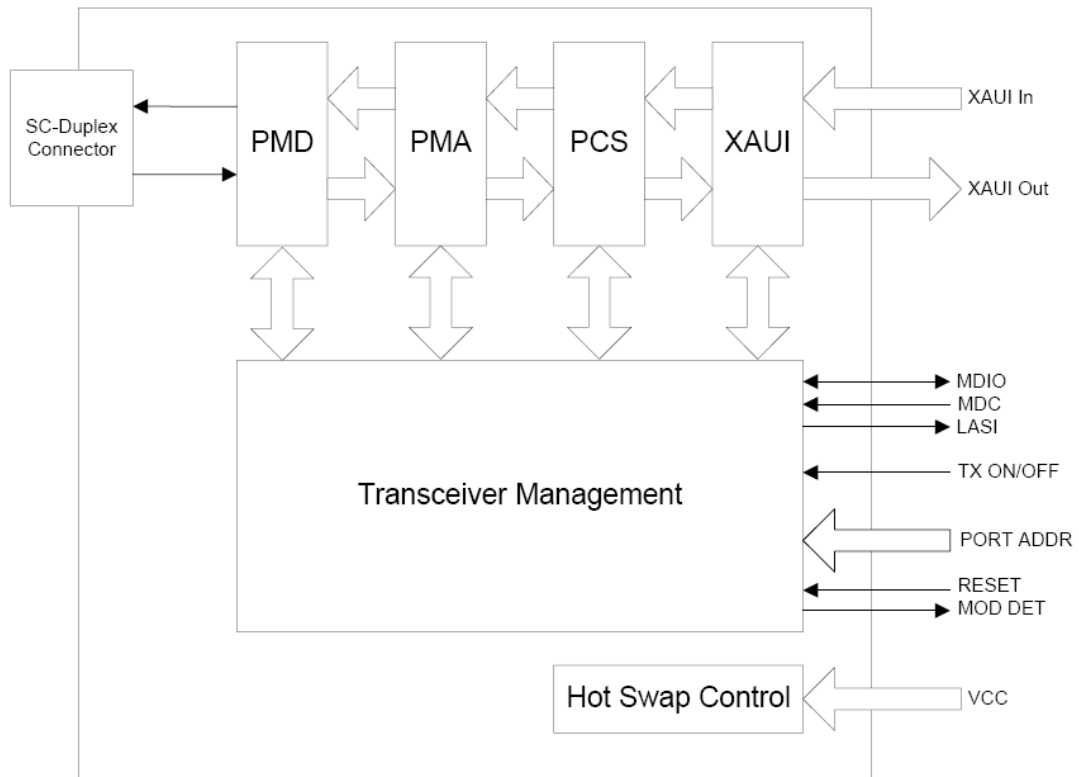

**Figure1.** Functional Diagram of Typical X2 Style Transceiver

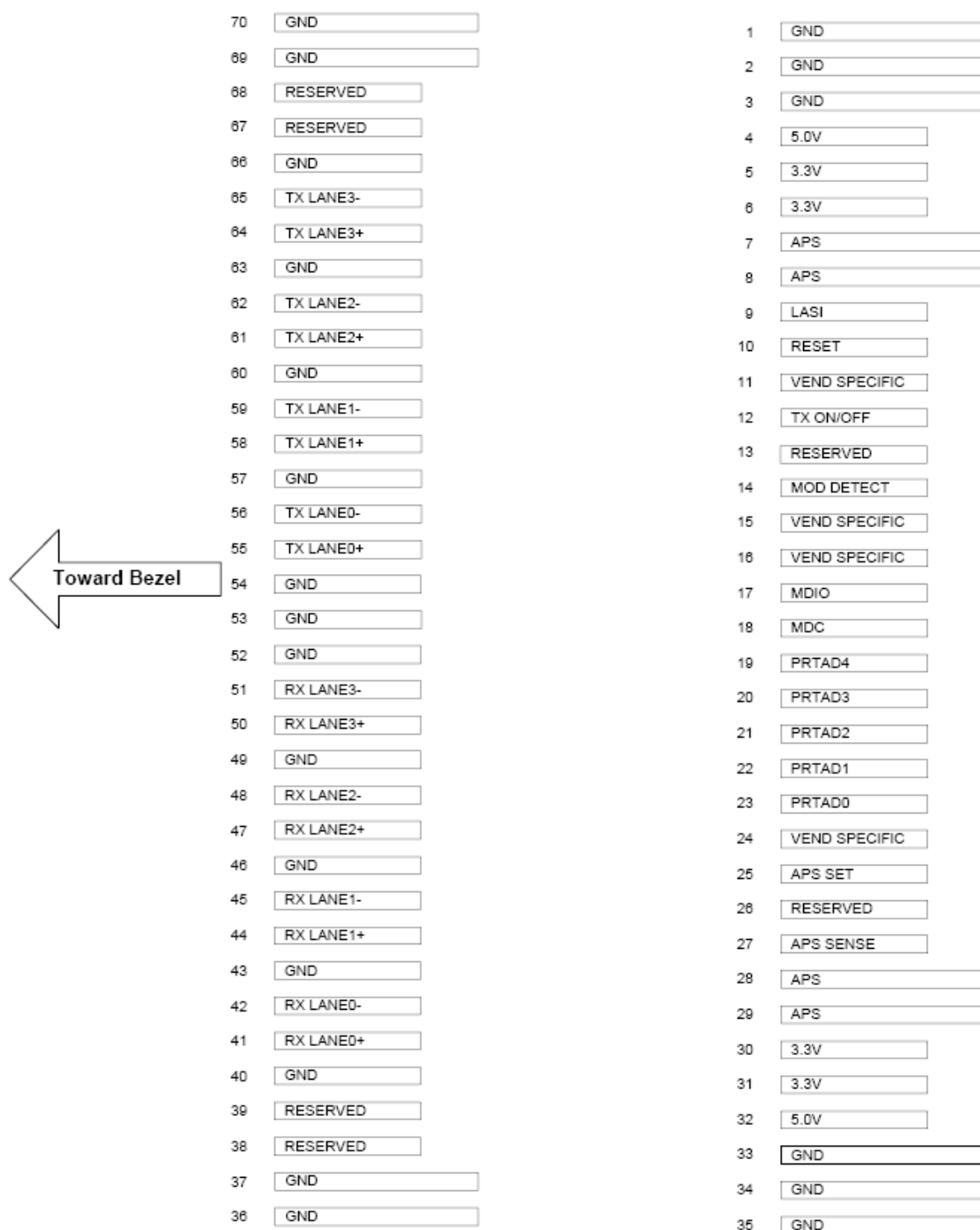

Figure2.Electrical Pin-out Details

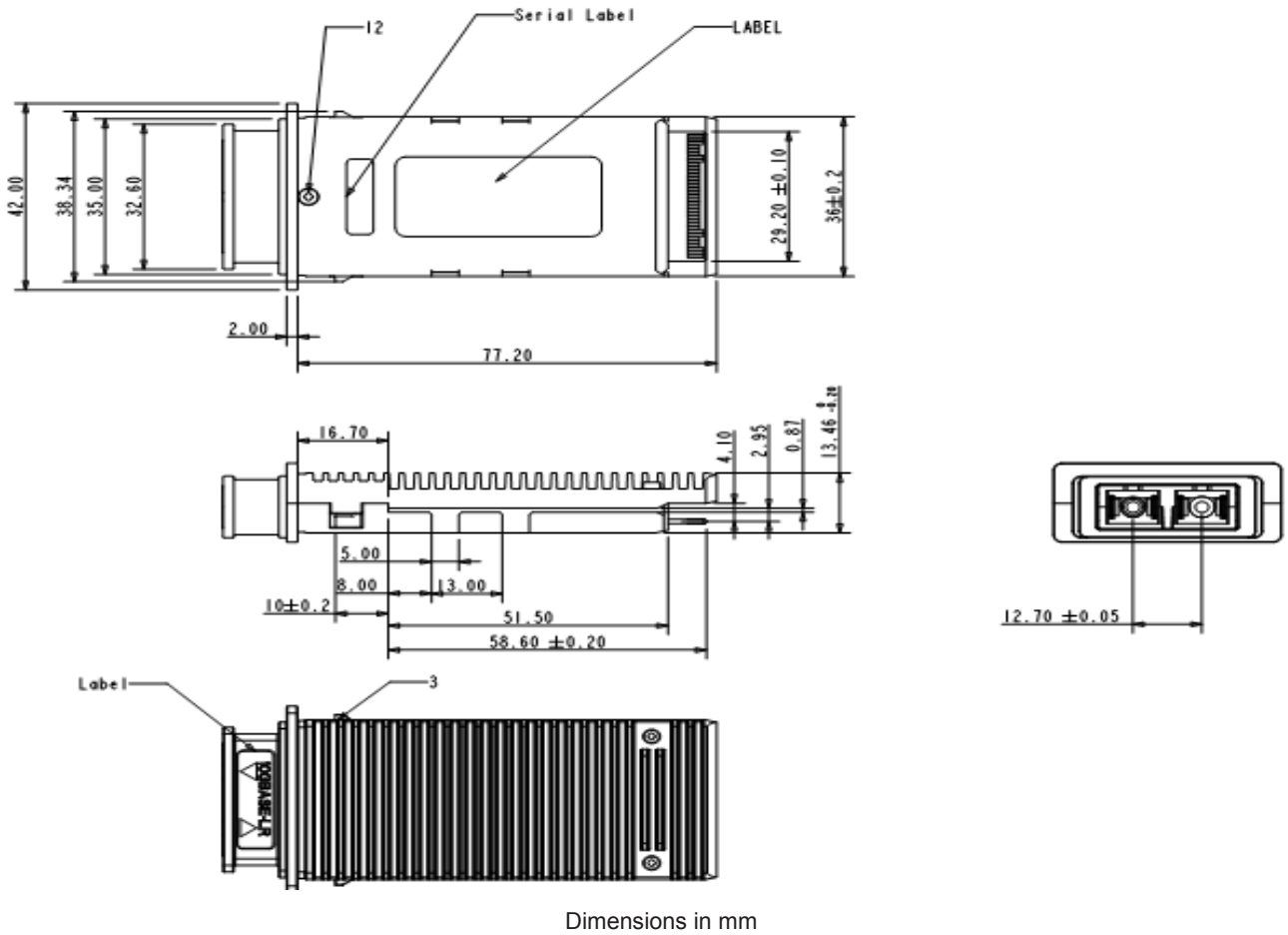

Figure3. Mechanical Dimensions

**Regulatory Compliance**

HE-LINK X2 Transponder is designed to be Class I Laser safety compliant and is certified per the following standards:

Feature	Agency	Standard	Certificate / Comments
Laser Safety	FDA	CDRH 21 CFR 1040 and Laser Notice No. 50	1120291-000



Product Safety	UL	UL and CUL EN60950-2:2007	WT10093765-D-E-E
Environmental protection	SGS	RoHS Directive 2002/95/EC	GZ1001008706/CHEM
EMC	WALTEK	EN 55022:2006+A1:2007 EN 55024:1998+A1+A2:2003 -	WT10093768-D-E-E

### Ordering information

Part Number	Product Description
HLX2-31192-LRM	1310nm, 10.3125Gbps, 220m, 0°C ~ +70°C

### Important Notice

Performance figures, data and any illustrative material provided in this data sheet are typical and must be specifically confirmed in writing by HE-LINK before they become applicable to any particular order or contract. In accordance with the HE-LINK policy of continuous improvement specifications may change without notice.

The publication of information in this data sheet does not imply freedom from patent or other protective rights of HE-LINK or others. Further details are available from any HE-LINK sales representative.

[sales@he-link.com.cn](mailto:sales@he-link.com.cn)  
<http://www.he-link.com.cn>